

MATERIALS

SOCKS: MINIMUM 200mm DIAMETER SYNTHETIC OR BIODEGRADABLE TUBES MANUFACTURED FROM NON-WOVEN OR COMPOSITE FABRIC SUITABLE FOR THE 'FILTRATION' OF COARSE SEDIMENTS.

FILL MATERIAL: STRAW, CANE MULCH, COMPOSTED MATERIAL (AS4454), COARSE SAND, OR CLEAN AGGREGATE.

STAKES: MINIMUM 25 x 25mm TIMBER.

INSTALLATION

1. REFER TO APPROVED PLANS FOR LOCATION AND INSTALLATION DETAILS. IF THERE ARE QUESTIONS OR PROBLEMS WITH THE LOCATION, DIMENSIONS OR METHOD OF INSTALLATION CONTACT THE ENGINEER OR RESPONSIBLE ON-SITE OFFICER FOR ASSISTANCE.

2. ENSURE THE SOCKS ARE PLACED INDIVIDUALLY OR COLLECTIVELY (AS A SINGLE SEDIMENT TRAP) SUCH THAT:
 (i) LEAKAGE AROUND OR UNDER THE SOCKS IS MINIMISED;
 (ii) ADJOINING SOCKS ARE TIGHTLY BUTTED OR OVERLAPPED AT LEAST 450mm;
 (iii) THE SURFACE AREA OF POTENTIAL WATER PONDING UP-SLOPE OF EACH SEDIMENT TRAP IS MAXIMISED;
 (iv) TO THE MAXIMUM DEGREE PRACTICAL, ALL SEDIMENT-LADEN WATER WILL PASS THROUGH THE FORMED POND BEFORE FLOWING OVER THE DOWN-SLOPE END OF THE SEDIMENT TRAP.

3. WHEN PLACED ACROSS THE INVERT OF MINOR DRAINS, ENSURE THE SOCKS ARE PLACED SUCH THAT:
 (i) THE CREST OF THE DOWNSTREAM SOCK IS LEVEL WITH THE CHANNEL INVERT AT THE IMMEDIATE UPSTREAM SOCK (IF ANY);

(ii) EACH SOCK EXTENDS UP THE CHANNEL BANKS SUCH THAT THE CREST OF THE SOCK AT ITS LOWEST POINT IS LOWER THAN GROUND LEVEL AT EITHER END OF THE SOCK.

4. IF STAKES ARE REQUIRED TO ANCHOR THE SOCKS, THEIR SPACING DOES NOT EXCEEDING 1.2m OR SIX TIMES THE SOCK DIAMETER (WHICHEVER IS THE LESSER). A MAXIMUM STAKE SPACING OF 0.3m APPLIES WHEN USED TO FORM CHECK DAMS.

MAINTENANCE

1. INSPECT ALL FILTER SOCKS PRIOR TO FORECAST RAIN, DAILY DURING EXTENDED PERIODS OF RAINFALL, AFTER SIGNIFICANT RUNOFF PRODUCING STORMS OR OTHERWISE AT WEEKLY INTERVALS.

2. REPAIR OR REPLACE DAMAGED SOCKS.

3. THE BULK OF THE SEDIMENT COLLECTED BEHIND THE FILTER SOCKS SHOULD BE REMOVED BY SHOVEL AFTER EACH STORM EVENT.

4. REMOVE COLLECTED SEDIMENT AND DISPOSE OF IN A SUITABLE MANNER THAT WILL NOT CAUSE AN EROSION OR POLLUTION HAZARD.

REMOVAL

1. ALL SAND, SOIL, SEDIMENT OR MUD MUST BE PHYSICALLY REMOVED FROM SEALED SURFACES, FIRST USING A SQUARE-EDGED SHOVEL, AND THEN A STIFF-BRISTLED BROOM, AND THEN BY A MECHANICAL VACUUM UNIT, IF AVAILABLE.

2. IF NECESSARY FOR SAFETY REASONS, THE SEALED SURFACE SHALL ONLY BE

WASHED CLEAN AFTER ALL REASONABLE EFFORTS HAVE BEEN TAKEN TO SHOVEL AND SWEEP THE MATERIAL FROM THE SURFACE.

3. DISPOSE OF COLLECTED SEDIMENT IN A SUITABLE MANNER THAT WILL NOT CAUSE AN EROSION OR POLLUTION HAZARD.

4. ALL SYNTHETIC (PLASTIC) MESH OR OTHER NON READILY BIODEGRADABLE MATERIAL MUST BE REMOVED FROM THE SITE ONCE THE SLOPE OR DRAIN IS STABILISED, OR THE SOCKS HAVE DETERIORATED TO A POINT WHERE THEY ARE NO LONGER PROVIDING THEIR INTENDED DRAINAGE OR SEDIMENT CONTROL FUNCTION.

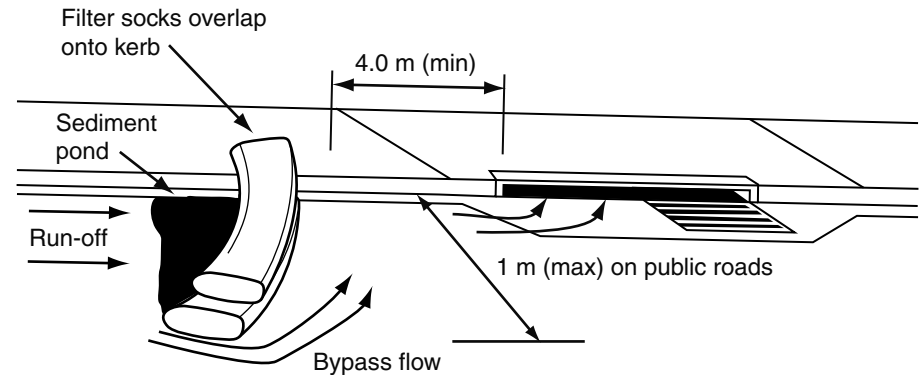

(a) On-grade kerb inlet sediment trap

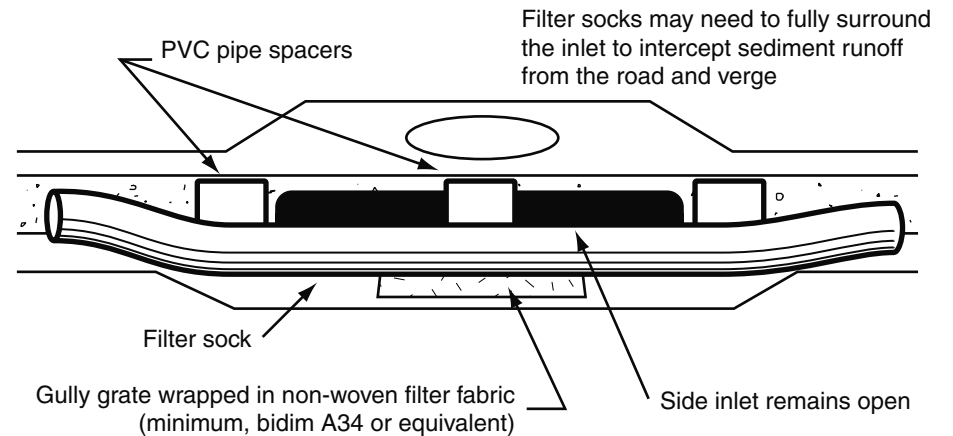

(b) Sag inlet sediment trap

Drawn:	Date:	Kerb Inlet Sediment Traps	ESC-03
GMW	Dec-09		